



Paper Discusses Circuitry for Quantum Computing

Date: Tuesday, Oct 23 @ 11:04 EDT

Topic: Archive

ANN ARBOR-The next radically different means of information processing will be quantum computing, which researchers say will use the principles of quantum mechanics to perform complex calculations in a fraction of the time needed by the world's fastest supercomputers.

A paper published recently in Physical Review Letters (Nov. 4 issue) has proposed an experimentally realizable circuit and an efficient scheme to implement scalable quantum computing. The ability to scale up the technology from the one or two-qubit experiments that are common in the laboratory to systems involving many qubits is what will finally make it possible to actually build a quantum computer.

"Scalable quantum computing with Josephson charge qubits," was written by Franco Nori of the University of Michigan Physics Department and the Institute of Physical and Chemical Research (RIKEN) and two colleagues, J.Q. You from the institute and J.S. Tsai from the institute and the NEC Fundamental Research Laboratories.

Quantum computing is very different from the standard computers used today. Today's computers process information using bits, each one equal to either 0 or 1. Quantum information processing uses quantum versions of these bits, individual atoms or subatomic particles called qubits. These qubits can be equal to 0, to 1, or even both 0 and 1 at the same time. The ability to manipulate these superpositions of 0 and 1 is what will allow quantum computers to process complex information so quickly, since any given qubit can occupy either position.

In order to implement quantum information technology, it will be necessary to prepare, manipulate and measure the fragile quantum state of a system. "The first steps in this field have mostly focused on the study of single qubits," Nori said. "But constructing a large quantum computer will mean scaling up to very many qubits, and controlling the connectivity between them. These are two of the major stumbling blocks to achieving practical quantum computing and we believe our method can efficiently solve these two central problems. In addition, a series of operations are proposed for achieving efficient quantum computations.

"We have proposed a way to solve a central problem in quantum computing - how to select two qubits, among very many, and make them interact with each other, even though they might not be nearest neighbors, as well as how to perform efficient quantum computing operations with them," Nori said.

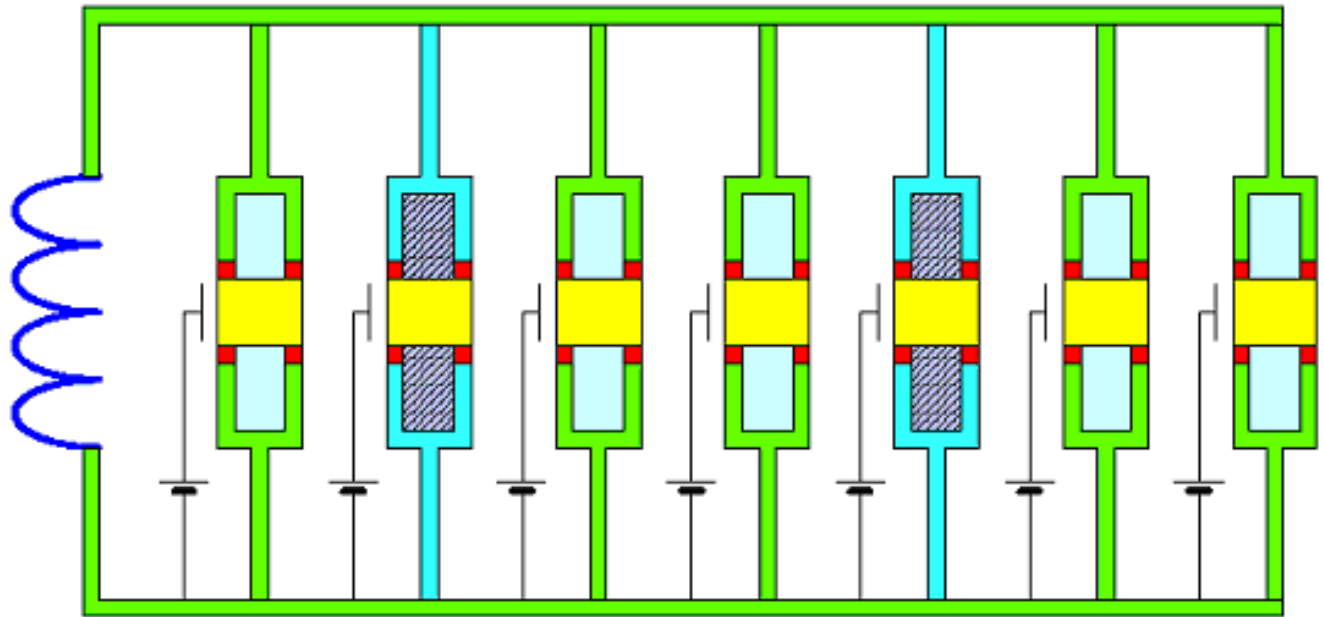

Diagram illustrating the operation of the system

This article comes from Supercomputing Online
<http://www.supercomputingonline.com>

The URL for this story is:
<http://www.supercomputingonline.com/article.php?sid=2756>